



NFC-500H-F-UL

CONVENTIONAL FIXED TEMPERATURE HEAT DETECTOR INSTALLATION GUIDE

DESCRIPTION	TECHNICAL DATA	
<p>NEVERFIRE heat detectors are low profile and have dual LEDs with 360-degree visibility, they are flashing in standby state but in fire state, they light up continuously in red. All data is written on the detector with lasers so that it cannot be erased or changed at all., these detectors will raise an alarm when the detector reaches 57°C. NEVERFIRE heat detectors uses a signal thermistor to sense the air temperature at the detector position.</p> <p>The thermistor is connected in a resistor network, which produces a voltage output dependent on temperature.</p> <p>NFC-500H-F-UL fixed Temperature Heat detector have been designed to EN54-5 and certified CE.</p>	Model	NFC-500S-UL
	Operating Voltage	9~33V DC from fire alarm control panel IDC
	Standby current	40 μA
	Surge current	4 μA
	Alarm current	15 mA
	Startup time	10seconds
	Thermal Rating	57°C (134.6°F)
	Remote Output	15mA max. open collector
	installation space	6m between each detector
	OPERATING CONDITION	
	Storage Temperature Range	-10°C to 50°C (14°F to 122°F)
Operating Temperature Range	0C to 45°C (32°F to 113°F)	
Operating Humidity Range	0%-95% Relative Humidity, non-condensing	
MECHANICAL SPECIFICATIONS		
Ingress Protection Rating	IP42	
Material	- Detector Housing: ABS (Fire Proof Plastic) -Terminals: Iron Nickel plated -stainless Steel	
Color	White	
Diameter	100mm Dia.	
Height	55mm with base	
weight	145g with base	
Packaging	90Unit\Carton	
Carton Dimensions	55*33*38cm	

FEATURES

- √ Superior performance and reliability.
- √ Attractive new design.
- √ Meet EN54-5 Requirements.
- √ Remote alarm indicating LED output.
- √ Low power consumption
- √ Two-wire, plug-in conventional detection technology.
- √ Designed for Fast and easy installation
- √ Wide angle LED's visibility (dual red color indication).
- √ Compatible with most of fire alarm panels
- √ 4" mounting base detector.
- √ Compatible with all NEVERFIRE conventional bases.
- √ Simplified sensitivity measurement.
- √ Removable detector cover and chamber for easy cleaning.
- √ High signal-to-noise ratio and sensitivity stability are effective in a wide range of environmental conditions.

DETECTOR'S BOTTOM AND ORIENTATION BASE

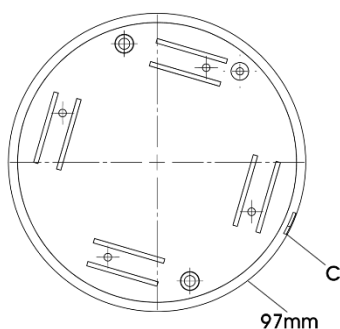

Fig.1 Bottom of the detector

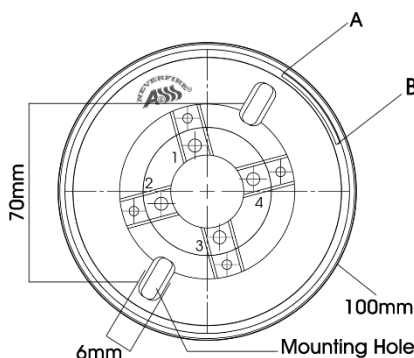

Fig.2 Orientation base

1. Remote indicator (-)
2. Zone (+)
3. Remote indicator (+) / Zone out
4. Zone (-) In / out



This Terminal base is matches with NEVERFIRE detectors only.

NFC-500H-F-UL

CONVENTIONAL FIXED TEMPERATURE HEAT DETECTOR INSTALLATION GUIDE

WIRING AND MOUNTING

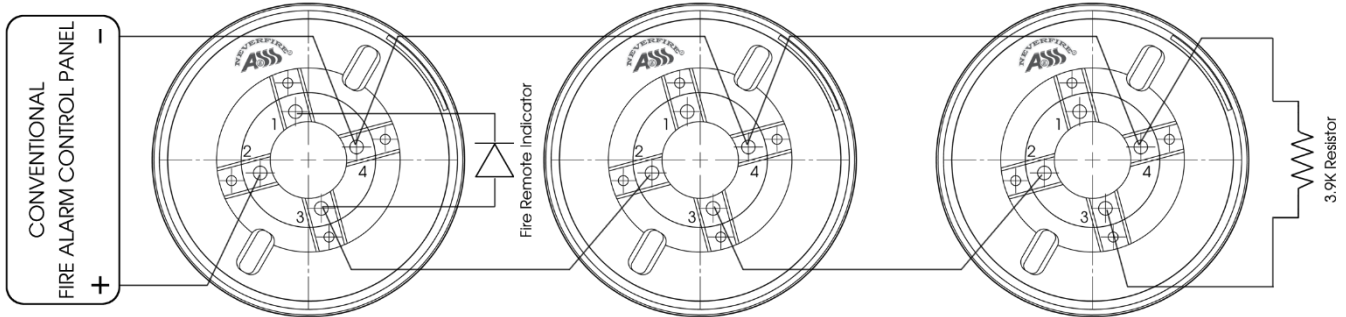

Fig.3 NFC-500H-F-UL Wiring

As Showing in Fig. 3 There are four terminals with numbers on the base, Terminal no.2 connects with the anode of the output end of compatible FACP, Terminal No.3 connects with terminal No.2 of the next base as output, Terminal No.4 connects with terminal No.4 of the next base and the cathode of the output end of compatible FACP, Terminal No. 3 with terminal No.1 connected to LED Indicator.

A 3.9k/1w terminal resistor can be connected between terminal No.3 and No.4 of the last base in a loop.

NOTE

Before Installing the detector, disconnect the power from the loop and verify that all bases are securely installed and that the wiring polarity is correct at each base.

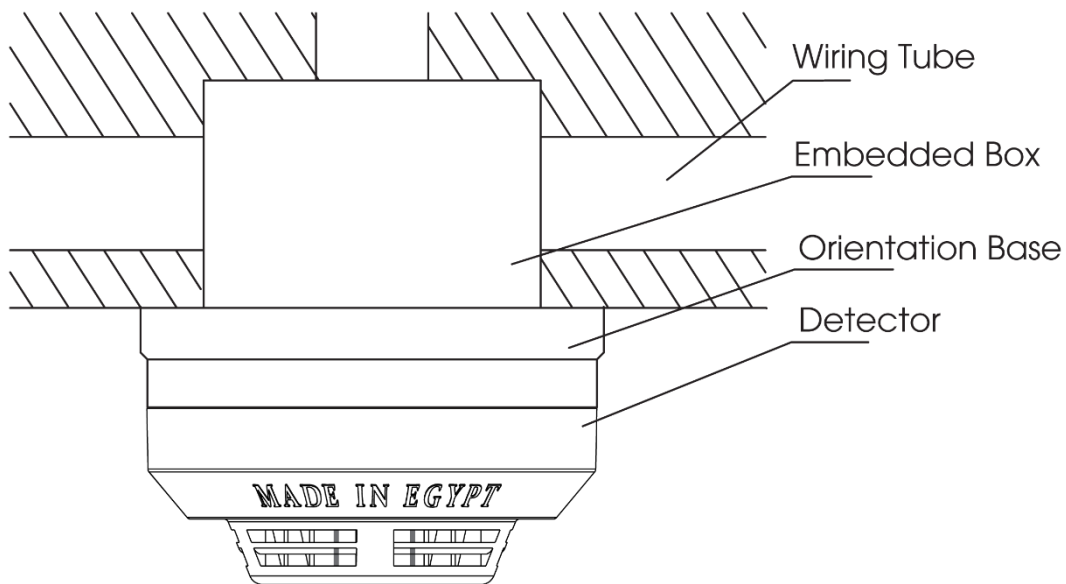

Fig.4 NFC-500H-F-UL Mounting

There are 3 marks on the orientation base and the detector bottom to show the installation direction. "A" and "B" marks on the orientation base of the detector and "C" mark on the bottom of the detector. when installing aligning the mark "C" to "A" and clockwise to "B", then the detector is installed.



NFC-500H-F-UL

CONVENTIONAL FIXED TEMPERATURE HEAT DETECTOR INSTALLATION GUIDE

During mounting the detector, some points should be put in consideration as the following: -

- 1) The horizontal distance from the detector to the wall or the girder should not be less than 0.5m.
- 2) There should not be any obstruction within 0.5m around the detector.
- 3) The horizontal distance from the detector to the blast hole of any air-conditioner should not be less than 1.5m; that to the multi-hole ceiling blast should not be less than 0.5m.
- 4) When installing detectors on corridor ceilings not wider than 2m, they should be placed in the middle.
The spacing should not be more than 9m. The distance from the detector to end wall should not be more than half of the spacing.
- 5) The detector should be installed horizontally. If it has to be installed aslant, the gradient angle should not be more than 45°.

TESTING

1. All the alarm signal services, releasing device and extinguisher system should be disengaged during the test period and must be re-engaged immediately at the conclusion of testing.
2. After energizing the detector head for approximately 30 seconds, check to see the indicator red LED flashing once every 5 seconds. If red LED fails to flash, it indicates the non-functioning of the detector or faulty wiring. Re-check the wiring or replace the detector if necessary.
3. The detector to be tested should be subject to a flow of warm air at a temperature of between 56°C and 80°C.
(This requirement can be met by some domestic hair dryers)

Proceed as follows:

1. Switch on the warm airflow and check that temperature is correct and stable.
2. From a distance of several inches, direct the airflow at the guard protecting the thermistor.
3. Upon alarm immediately remove the heat source and check that the red LED of the detector is illuminated. Reset the detector from the control panel.
4. If detector fails to go into alarm mode it is too insensitive and needs to be returned to the distributor for servicing.
5. After testing, check that the system is set for normal operation and notify the appropriate authorities that the testing operation is complete and the system is active again.

MAINTENANCE

Before removing a detector for maintenance, notify the appropriate authorities that fire alarm system or a specific zone of the system will be temporarily out of service., Disable the zone or system undergoing maintenance to prevent unwanted alarms.

At least once every 12 months remove the detector for close inspection and, if found to be necessary cleaning, clean the detector more frequently if environment contains appreciable sources dirt or corrosive agents.

To maintain a heat detector the following steps can be

1. Remove the detector head from its base.
2. Do not damage the heat sensor for the heat detector models.
3. Check that thermistor bead is free from dirt or dust, if necessary; gently wipe it with a clean tissue paper.
4. After cleaning the detector, be sure not to tangle the leads of thermistor.
5. Check thermistor head in standing upright in the center of its plastic protective guard.
6. Install the detector into its base again.
7. Test the operation of the heat detector.



ISO9001

CE QACE202401069

NFC-500H-F-UL

CONVENTIONAL FIXED TEMPERATURE HEAT DETECTOR INSTALLATION GUIDE

8. Enable the zone or system again and notify the appropriate authorities that the maintenance operation is complete and the system is active again.
9. Enable the zone or system again and notify the appropriate authorities that the maintenance operation is complete and the system is active again.

Heat detectors are designed to be as maintenance-free as possible. However, dirt or corrosive agents can accumulate inside a detector's sensing head and influence its sensitivity.

They could reduce the amount of warning time given in case of a fire. Therefore, detectors should be tested periodically and maintained at regular intervals.

WARRANTY

NEVERFIRE warrants that product from defects in design, materials and workmanship during the warranty period ensuring customers' confidence in product quality and performance.

For comprehensive information, including installation guidelines and compatibility details, please consult NEVERFIRE Installation Manual or reach out to our technical support team. Anybody, including the agents, distributors or employees, is not in the position to amend the contents of this warranty.

NOTE

1. The detector should be tested regular, at least 6 months.
2. We recommend that the dust cover should not be removed until the project has been put in usage to prevent airborne dust particles from entering the detector.
3. To make sure the detector is always in good operation state, please maintain it according to NEVERFIRE's recommendations and relative national code.